

## Specifications

### Wrapping

Package size ..... Width: 10-190 mm (0.4-7.5 inches)  
 Height: 1-40 mm (0.04-1.6 inches)  
 Depth: 10-150 mm (0.4-5.9 inches)  
 Note: when using a larger sheet

Wrapping speed ..... Max. 16 packages/min.  
 Wrapping range ..... 50g-600g  
 Number of film roll ..... One roll  
 Film width ..... 245 mm (9.6 inches)  
 Sheets ..... DIGI genuine polyolefin sheets  
 • Large: 220x180mm (8.7x7.1 inches)  
 • Small: 220x140mm (8.7x5.5 inches)

### Weighing

Interval type	Multi-interval	Single interval
Capacity	Max. 3/6kg	Max.15 lb
Scale interval	e=1/2g	e=0.005 lb
Weighing range	20g-6kg	0.1-15 lb

### Thermal printer

Label type	Linerless label
Dot density	12 dot/mm (300dpi)
Label width	59mm (2.3 inches)
Label length	20-500mm/ 0.79-19.7 inches
Max. print length	300mm (11.8 inches)
Print speed	60-140mm/sec.

### Operation console

Display panel ..... TFT LCD color (10.4 inches) touch panel  
 Operation keys ..... Mechanical keys and touch screen  
 Memory for programmable files ..... 8.8GB

### General

Power source and power consumption ..... AC 100-120V; 50/60Hz; 1.2kVA, 1.2kW  
 ..... AC 120V; 60Hz; 1.2kVA, 1.2kW  
 ..... AC 220-240V; 50/60Hz; 1.2kVA, 1.2kW  
 Net weight ..... 85.5kg

### Options

• Customer side display (7 inches)



## Dimensions

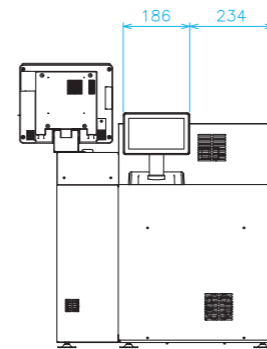
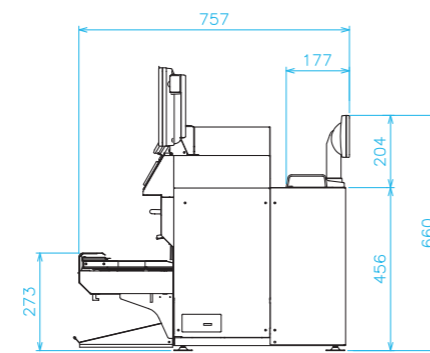
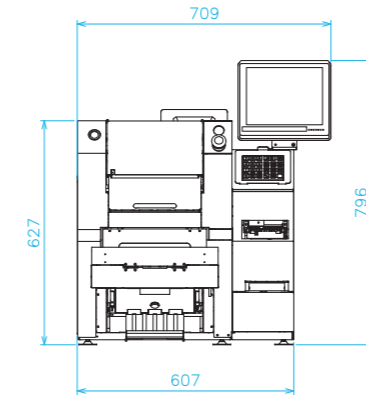
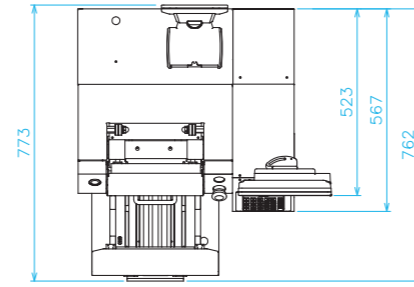

Unit = mm



# SWS-5600

Trayless packaging system



\*Specifications are subject to change without prior notice.

TERAOKA SEIKO CO., LTD.

13-12 Kugahara 5-chome, Ohta-ku,  
 Tokyo 146-8580 JAPAN  
 www.digisystem.com

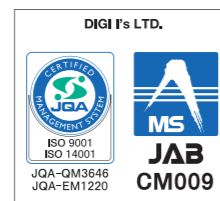

A1506CDMP

Searching for a New Balance

# SWS-5600 enables both on-site-packaging and prepackaging of your products for shoppers' convenience

The high-performance, easy to use compact system can be installed anywhere in a store.

Using the SWS-5600 at a service counter, shoppers can enjoy communicating with a shop attendant while selecting products.

By providing prepacked products, shoppers can quickly grab their choice and go.



Customer side display is available as a variation of the SWS-5600 for use at a service counter.

Visually appealing labels can be used as shelf labels for easier maintenance.

**WENSLEYDALE**  
WITH CRANBERRY & WALNUT

USE BY **09.06.15** PACKED ON 02.06.15 0066

0 200065 404670

PRICE/kg WEIGHT **\$18.32 0.255kg**

**TOTAL PRICE \$4.67**

**DIGI** DIGI SUPERMARKET  
5-13-12 KUGAHARA TOKYO

**INGREDIENTS:** WENSLEYDALE CHEESE (MILK), WALNUT, SWEETENED DRIED CRANBERRIES (SUGER, CRANBERRIES SUNFLOWER OIL), FRUCTOSE

**ALLERGY ADVICE:** FOR ALLERGENS SEE INGREDIENTS IN INVERSE

**ARTISANAL SALAMI**

USE BY **09.06.15** PACKED ON 02.06.15 0067

0 200065 504851

PRICE/kg WEIGHT **\$19.10 0.254kg**

**TOTAL PRICE \$4.85**

**DIGI** DIGI SUPERMARKET  
5-13-12 KUGAHARA TOKYO

**INGREDIENTS:** PORK MEAT, SALT, FLAVOURS, RED WINE, DEXTROSE, SPICES



## Space saving design

The compact unit only requires a foot print of 607(W) x 773(D)mm, and can be installed on a workbench.

## Environmental friendliness

The system benefits consumers by using paper sheets in place of trays, which reduces CO<sub>2</sub> emissions, while heat sealing on all four sides assures secure packaging.

## High-performance

Weighing and packaging are done automatically at rates of up to 16 packages per minute. Productivity is increased with the reduced need for film roll replacement.

## Consumer convenience

Use of trayless packaging makes products more compact which is easier for consumers to carry home, requires less refrigerator storage space, and reduces household waste.



## Featuring linerless labeling

A new dimension for backroom and store-front operations. Eliminate liner waste and increase flexibility and profit.

**30% reduction**

ex. 86mm ▶ 60mm

## Label format flexibility

A continuous strip of linerless labels is cut every time a label is printed. The auto-cut feature allows variable label layouts and sizes to be used from one roll of linerless labels.

## No more wasted white space on big labels

The auto-label-sizing feature eliminates unused space on the label and automatically adjusts the label size. This reduces the label cost and makes labels more attractive.



Actual size