

# Free-Fall Metal Detector

## M6<sup>II</sup>



Eliminating foreign bodies in raw material process

## Free-Fall Metal Detection — ideal for pre-packaging inspection of dry products — is now available in the M6-h series.



### Increasing demand for foreign body inspection in raw material process

Due to the soaring prices of raw materials in recent years, the sources of procurement are forced to be diversified, which makes it more difficult to manage foreign body control for them. Introducing metal detection not only after product packaging but also in the raw material process has the following advantages.

#### Avoid risk of foreign body spreading and outflowing

If a metal piece is in the raw material, it may be crushed in the production process and spread widely. In this case, the crushed pieces would become even smaller and undetectable by downstream inspection equipment.

#### Reduction of product waste loss

If foreign body is found during post-packaging inspection or after product shipment, the entire production lot may be required to be re-inspected or discarded.

#### Achieve high detection performance as it is unaffected by packaging material

The free-fall metal detector is particularly suitable for vertical form fill seal (VFFS) packaging line in which metalized film packaging materials are used.

#### Protection of downstream production equipment

If hard metal pieces get into the production line, it may damage the production equipment.



### Equipped with M6-h high sensitivity detection head

The M6-h head, which has been proven with high detection performance and stability on the actual production line, has been engineered and optimized for free fall inspection. False rejections have been significantly reduced by strengthening the resistance to external noise. Stable operation can be realized while the head is incorporated into existing production line.

#### Industry-leading detection sensitivity\*

Advanced signal processing minimizes product effect for the best contaminant detection.

Furthermore, inspection can be started without complicated product settings using product samples.

\*Based on our internal survey

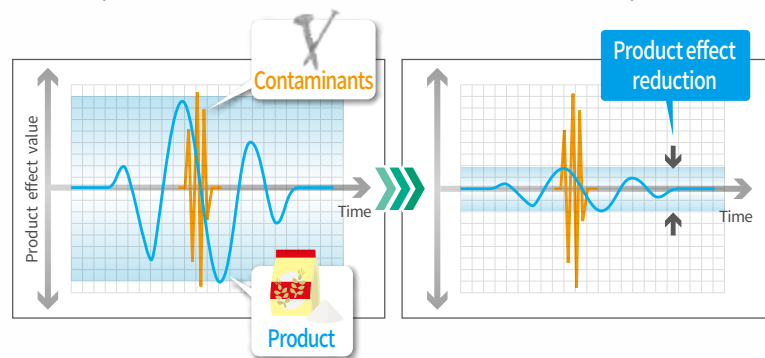

#### Vibration resistant

The signal processing technology is also effective to reduce vibration noise, and stability against physical vibration has been improved.

#### Resistance to noise from peripheral devices

External noise from inverters, power sources, etc. can cause false rejections with metal detectors. Due to the enhanced signal processing, resistance against external noise has been greatly improved to maximize detection performance and inspection reliability.

Vibration from peripheral devices      External noise from inverters and power sources

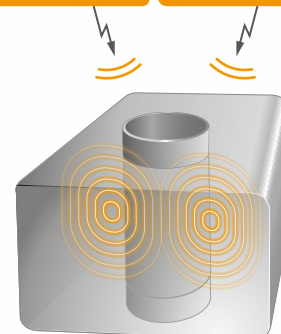

## Advanced self-monitoring functions

The system constantly self-monitors internal status of metal detector to ensure if the equipment is operating normally. In addition, it is equipped with a function that automatically diagnoses whether the detection performance maintains the same detection sensitivity as when it was introduced.

### Automatic monitoring of internal status of equipment

The function constantly monitors the internal conditions of equipment during the production. In the event of any malfunctions, the system instantly gives an error message to alert operators.

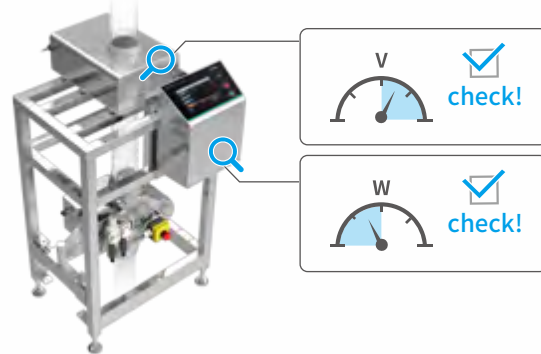

### Self-diagnosis of detection performance

The system can generate artificial signals simulating metal contamination, which allows operators to confirm the equipment maintains the same performance level as was initially installed in the production line.

\*This function does not include confirmation of rejector operation.

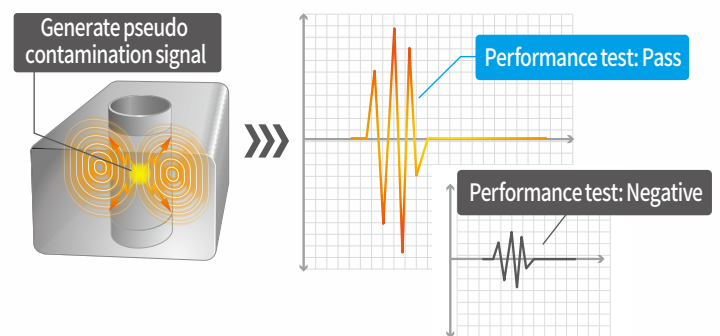

## Rejection unit for powder/granule products

\*Optional

The rejector is equipped with fail-safe mechanism that is safe even if unexpected troubles such as power interruption. The design is user-friendly and easy to clean.

### Prevent outflow of foreign bodies

The fail-safe design is contributing to it not only during normal operation but also when unexpected troubles occur.

- Force the rejection gate to stand by on the reject side when the power is shut down or other abnormalities occurs.
- Position monitoring of rejection gate
- Automatic rejection operation check at start-up
- Air pressure monitoring

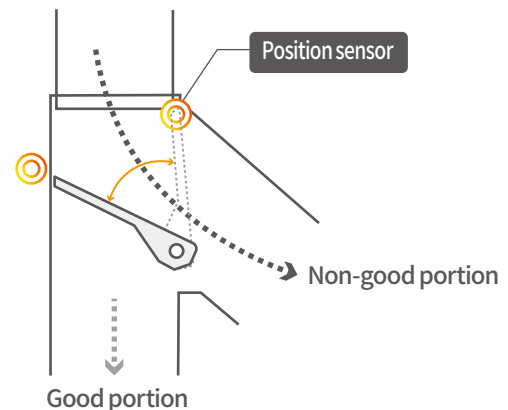

### Easy to clean

The adapters between the rejection unit and the peripheral equipment can be attached and detached without using tools. In addition, as methods of removing the rejection unit from the line, we can propose the following swing mechanism, the slide-rail mechanism, or other methods according to the layout of the production line.

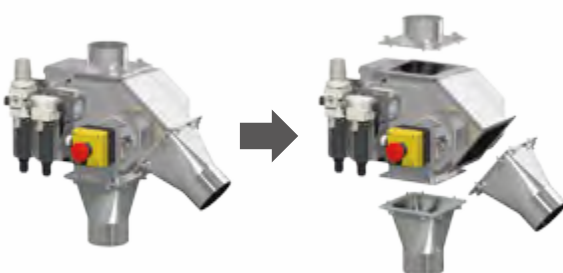

Attaching/detaching adapters

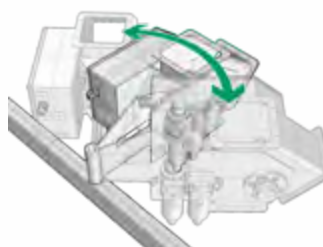

Swing mechanism

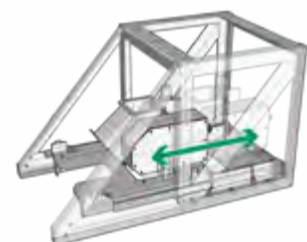

Slide-rail mechanism

## Flexible Integration into the existing production line

### Space saving and easy wiring

By providing the detection head, indicator, and rejection unit in an independent and compact unit, the integration will be easy and space-saving. The detection head and the rejection unit can be connected with the indicator by a single cable.



### Proposing the best customization for your production line and product to be inspected

We propose the optimum installation method according to the customer's production environment, line layout, product physical characteristics, production volume, etc.

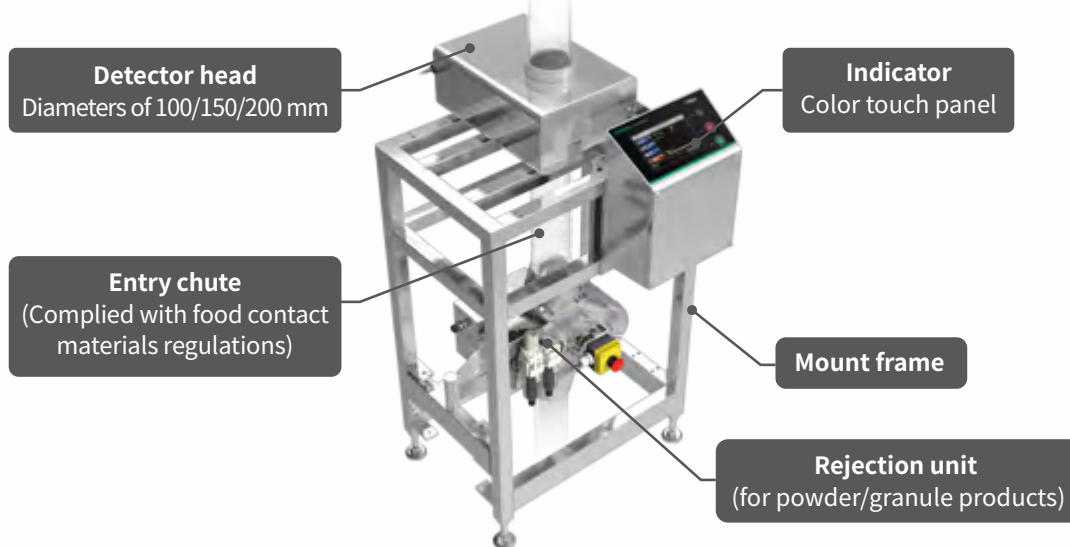

## Integration examples

- Integration with a vertical form fill seal (VFFS) packaging machine and a multihead weigher

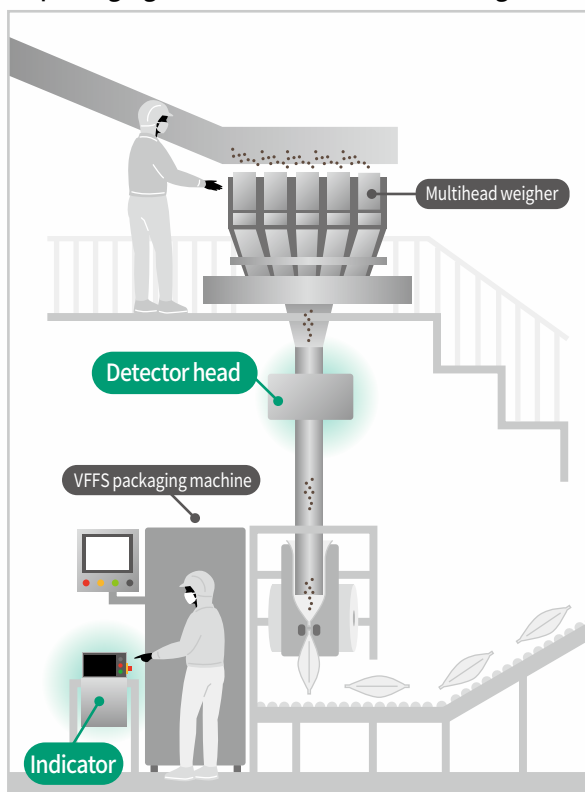

- Integration with a raw material tank and a filling and packaging machine

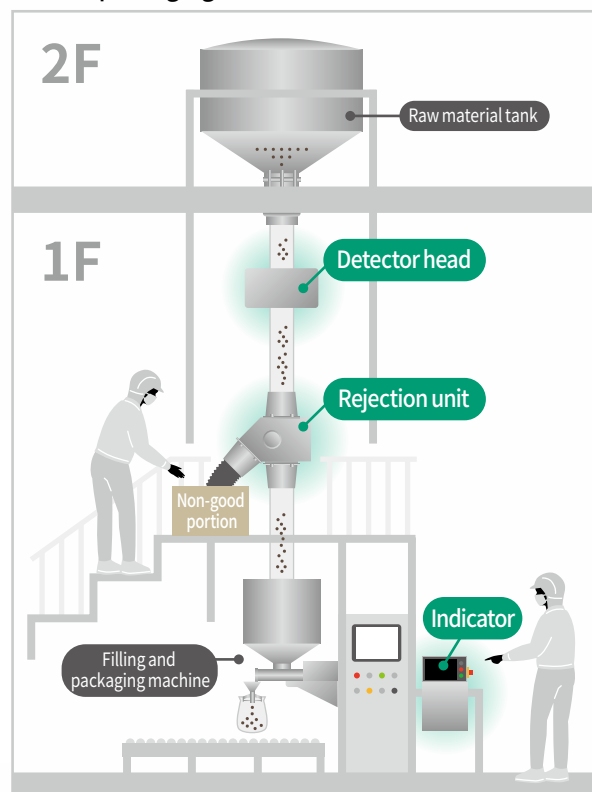

## Major Specifications

### M6 Free-Fall Model

#### External Dimensions

KDS0010VFW  
KDS0015VFW  
KDS0020VFW

Model	D1	D2
KDS0010VFW	116 dia.	100 dia.
KDS0015VFW	166 dia.	150 dia.
KDS0020VFW	216 dia.	200 dia.

Model	L1	L2	L3
KDS0010VFW	404	142	262
KDS0015VFW	454	167	287
KDS0020VFW	504	192	312

Model	L4	L5
KDS0010VFW	176.8	284
KDS0015VFW	240	334
KDS0020VFW	290	384

Detector head

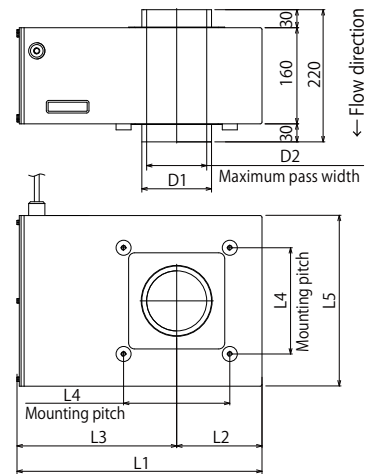

Indicator

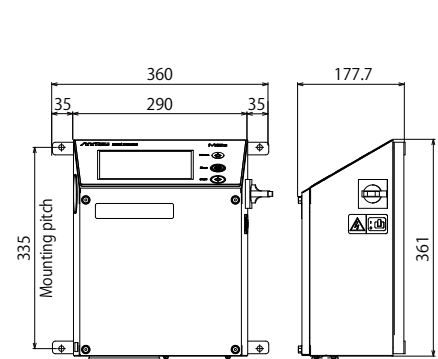

Rejection unit  
(optional)  
KRA9610CW

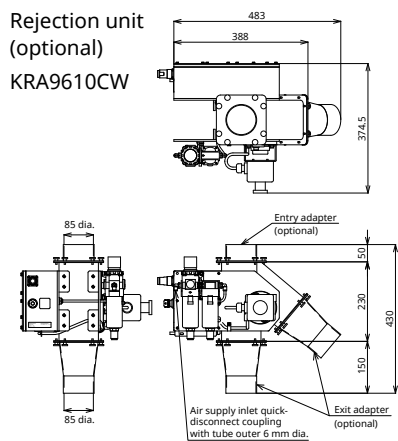

Rejection unit  
(optional)  
KRA9615CW

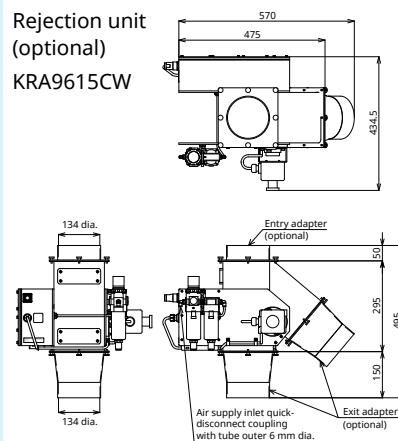

Rejection unit  
(optional)  
KRA9620CW

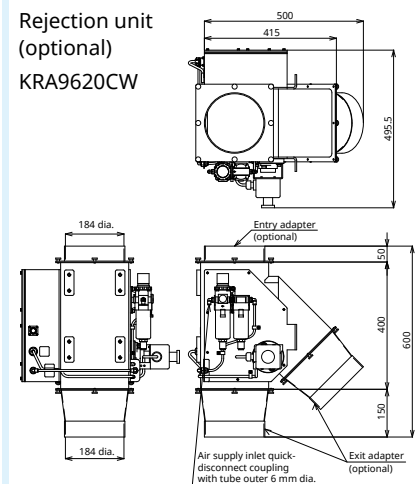

Units : mm

## Specifications



Model	KDS0010VFW	KDS0015VFW	KDS0020VFW
Opening inner diameter	100 mm dia.	150 mm dia.	200 mm dia.
Display	7-inch color TFT LCD		
Operation method	Touch panel (Start, Stop, and Home are direct push buttons)		
Preset memory	Maximum 200		
Product	Dry products		
Maximum throughput capacity <sup>1</sup>	21,000 ℓ/h	47,000 ℓ/h	84,000 ℓ/h
Metal detection	Rejection signal output and beep (Reject when the optional rejection unit is attached)		
Air requirements for the rejection unit (optional) <sup>2</sup>	KRA9610CW 0.5 MPa to 0.9 MPa, 0.4 ℓ/cycle [A.N.R.]	KRA9615CW 0.5 MPa to 0.9 MPa, 0.6 ℓ/cycle [A.N.R.]	KRA9620CW 0.5 MPa to 0.9 MPa, 0.6 ℓ/cycle [A.N.R.]
Air inlet for the rejection unit (optional) <sup>2</sup>	Tube having outer diameter of 6 mm		
Power supply	100 Vac to 120 Vac +10% -15% or 200 Vac to 240 Vac +10% -15%, single phase, 50/60 Hz		
Power consumption	60 VA, rush current 50 A (typ.) (20 ms or less)		
Mass	Detector head	26 kg	33 kg
	Indicator	13 kg	39 kg
	Rejection unit (optional)	20 kg	26 kg
Environmental conditions	Standard mode: 0°C to 40°C (temperature range during use must be within ±15°C); High sensitivity mode: 0°C to 30°C (temperature range during use must be within ±5°C); Relative humidity 30% to 85%, non-condensing		
Protection class	IP66 compliance		
Exterior	Stainless steel (SUS304)		
Data output	USB port (USB2.0), Ethernet interface (10BASE-T, 100BASE-TX)		

1: These are reference values. They depend on the particle size, physical properties, environmental conditions, and so forth.

2: The rejection unit is optional. It requires air supply.

Note: The noise level of KRA9610CW does not exceed 70 dB(A). The noise level of KRA9615CW and KRA9620CW is 71 dB(A) or less.



# The production line in the palm of your hand.

All your production data - anywhere, anytime

**QUICCA**  
Overall quality management and control system



## Visual information sharing to maximize plant production

QUICCA provides visualization of inspection system status, production data, and quality analysis. Installation is simple and inexpensive. QUICCA also ensures recording of daily operation check with inspection equipment, which contributes to HACCP management.

### Displays historical and current production status

High level production line overview showing: Conveyor on/off, production counts, and reject counts. Production information can be viewed simultaneously from multiple locations.



### Various reporting functions

You can search by period, inspection machine, lot number, and product name, and easily output the production status as a report, contributing to paperless operations.



Production results summary    Inspection system statistical reports    Reject history

### Centralized management of operation check history with inspection machines

You can easily find records of inspection machines such as number of rejects, operator info, test piece type, and inspection time. The credibility of the daily report is improved by preventing omissions and falsification of records, which ensures your HACCP management.

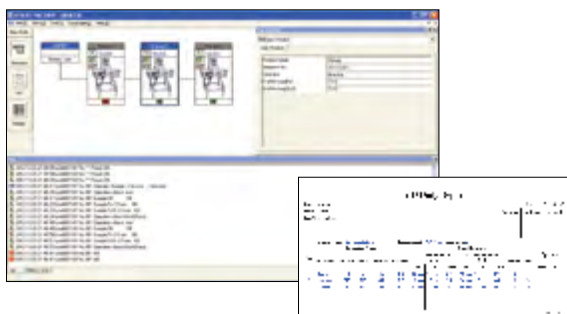

### Issuance of inspection report

It is possible to issue an inspection report indicating that the product has been inspected with inspection equipment properly operated by the HACCP management method. The format is customizable, but the inspection equipment records are immutable.

It would be useful for promoting the quality control system of your company to your customers.

\*Anritsu is not responsible for the inspection results by this documentation.







## ANRITSU CORPORATION

5-1-1 Onna, Atsugi-shi, Kanagawa, 243-8555, JAPAN  
TEL: +81-46-296-6699 FAX: +81-46-296-6786  
<https://www.anritsu.com/infivis>

**Anritsu Industrial Solutions (Shanghai) Co., Ltd.**  
Room 703-704, Sandhill Central, No.505 Zhangjiang Road, Pudong New Area, Shanghai 201210, P.R. China  
TEL: +86-21-5046-3066

**ANRITSU INFIVIS (THAILAND) CO., LTD.**  
700/678-679 Moo1, Amata City Chonburi Industrial Estate, Tambol Panthong, Amphur Panthong, Chonburi 20160 Thailand  
TEL: +66 38-447180 FAX: +66 38-447182

**ANRITSU INFIVIS B.V.**  
Grubbenvorsterweg 10 5928NX, Venlo, the Netherlands  
TEL: +31(0)20-2254220

**ANRITSU INFIVIS LTD.**  
Unit 3, Scott Road, Luton, LU3 3BF, United Kingdom  
TEL: +44(0)845 539 9729

**ANRITSU INFIVIS INC.**  
701 Innovation Drive, Elk Grove Village, IL 60007, U.S.A.  
TEL: +1-847-419-9729 FAX: +1-847-537-8266

© ANRITSU CORPORATION 2021  
ISO14001, ISO9001 Certified

• Some products shown in this catalog may not be available in your country or region. Contact our sales representatives for details.

• To ensure proper operation, read the Operation Manual before using the machine.

• In addition to daily inspection, a full maintenance inspection should be completed annually.

Specifications are subject to change without notice.

No part of this catalog may be reproduced without our permission.