



SM-6000 AI G

AI - Powered Smart Recognition Scale

YAKUDŌ

Odważne technologie



Searching for a New Balance

The Search Is Over.

SM-6000 AI G's built-in Edge computing AI module helps retailers harness the power of enterprise-grade cognitive intelligence, enabling rapid and accurate product identification for a seamless self-weighing experience.

Core Features

- **Fast Detection**
Search-free operation with <2 seconds average detection speed
- **High Accuracy**
Up to 97% accurate rate
- **Fast Deployment**
Deploy quicker with an Extensive collection of 1,500 pre-trained model
- **Reduce Shrinkage**
Product recognition & other integrated features prevent mis-selection or unintentional fraud
- **Self-Learning**
Accuracy increases with each use
- **No External Server**
Data collection & processing happen locally with edge computing

Operation



01 WEIGH

Place item onto the scale platter



02 SELECT

AI generates best-matched results for easy PLU selection



03 PRINT / SCAN

Print label and paste onto the bag. Alternatively, scan QR code on screen.



• Specifications are subject to change without prior notice

Sedex Member



DIGI SINGAPORE PTE. LTD.

4 Leng Kee Road #05-02/03/04/05/11/12
SIS Building SINGAPORE 159088
TEL : +65 6472 2996
SALES: +65 6378 5387
FAX : +65 6863 4614
URL : www.digisystem.com/sg/
E-MAIL : customer_support@sg.digi-group.com

TERAOKA SEIKO Co., Ltd.

13-12 Kugahara 5-chome, Ohta-ku,
Tokyo 146-8580, JAPAN
TEL : +81-3-3752-2131
FAX : +81-3-3752-5562
URL : www.digisystem.com

External Dimensions (mm)

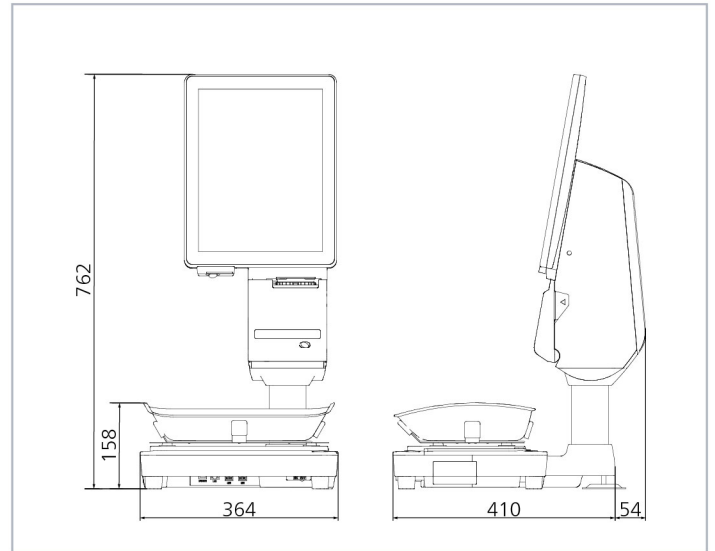

Specifications

Capacity	Resolution	Max 6kg	Max 15kg / 30lb	Max 30kg
Single Interval	1 / 3,000	e = 2g	e = 5g / 0.01lb	e = 10g
	1 / 6,000	e = 1g	—	e = 5g
	1 / 7,500	—	e = 2g	—
Capacity	Resolution	Max 3 / 6kg	Max 6 / 15kg	Max 15 / 30kg
Multi Interval	1 / 3,000	e = 1 / 2g	e = 2 / 5g	e = 5 / 10g

Model	SM-6000 AI G	
Dimension WxDxH(mm)	364 x 464 x 762	
Operator Display	15" TFT XGA with Capacitive Touch (768 x 1024)	
Camera	480p in resolution with built-in LED	
Label / Receipt	Types	Linerless With Auto-Cutter
	Roll Diameter	Max 95mm
	Roll Width	Max 62mm
	Print Width	Max 61mm
	Printing Speed	Max 150mm / second*
	Print Resolution	300 dpi
Power Source	Compliance to 80PLUS Power Saving**	
Operating Temperature	-10°C to +40°C	
Humidity	15% to 85% RH Non-Condensation	
Standard Interface	Ethernet 10 / 100 Base T, 4 x USB 2.0, RJ11	
Net Weight	16.7 kg	

Options	Wireless LAN IEEE 802.11 a / b / g / n / ac, InfoTag, e.Label with Hi-Touch, Base Station, Speed ID, BYO***, Contactless
Factory Option	Auto Tilt Sensor



- * To achieve maximum print speed, high sensitivity thermal paper is necessary.
- ** 100-120Vac Gold (North America, Canada and Japan)
210-240Vac Silver (European, UK and most of Asia)
- *** Plastic platter required.

YAKUDO
Odważne technologie

SM-6000 AI G / A / 1124S